

WOUD[®]

COLLECTION
TWO THOUSAND
SEVENTEEN

WELCOME TO
THE WOULD
UNIVERSE

MAKE
YOURSELF
AT HOME



SOROUND SIDE TABLE DESIGNED BY NUR



OUR DESIGNERS

This is our design team.

A diverse collection of upcoming talents and established designers from a wide range of countries. From Canada to Japan. Each with a distinctive and unique style but all with a coherent modern interpretation of the Scandinavian design heritage. Eager to discover and develop new ideas whether it being in form, function or choice of material.

Our designers are handpicked to ensure that they share and strengthen our vision of creating timeless design with great attention to detail and quality.

POIAT



FRAII



**ANNE
HOLM
AND
SIGRID
SMETANA**



**DANIEL
SCHOFIELD**



**SILJE
NESDAL**



**MADE BY
MICHAEL**



M-S-D-S



**LAURA
BILDE**



**MIKA
TOLVANEN**



**KEISUKE
KAWSE**



TERHEDEBRÜGGE



**PHILIP
BRO**



**TERKEL SKOU
STEFFENSEN**



**AMALIE
SKOV
RAHBÆK**



**BETTE
EKLUND**



**LÆRKE
BO
POULSEN**



**RIKKE
MALLING**



SIGNE HYTE



**MARTIN
ZANOLIN**



**NAOYA
MATSUO**



**EMILIE
STAHL
CARLSEN**



**ANN
KRISTIN
EINARSEN**



**MIKKO
LAAKKONEN**



KASPER NYMAN



NUR



**RØPKE DESIGN
& MOAKK**



JULIE TOLVANEN



**JEANETTE
HOLDGAARD**



**LEONARD
ALDENHOFF**



**RIKKE
FROST**



**SAYS
WHO**



**STEFFEN
JUUL**



**SPANT
STUDIO**

**AGATA
NOWAK**



**JANNIS
ELLENBERGER**



MIRROR BOX DESIGNED BY LAURA BILDE
MONO DINING CHAIR AND TAIL WING HOOKS DESIGNED BY KASPER NYMAN





VOWEL DESIGNED BY KEISUKE KAWASE



TÖJBOX SMALL DESIGNED BY MADE BY MICHAEL
S.A.C. CHAIR DESIGNED BY NAOYA MATSUO
ILLUSION HANGERS DESIGNED BY PHILIP BRO



TIMEWATCH DESIGNED BY AGATA NOWAK
TAIL WING HOOK AND PAUSE CHAIR DESIGNED BY KASPER NYMAN



ANNULAR PENDANT DESIGNED BY M-S-D-S
NAKKI DESIGNED BY MIKA TOLVANEN



MADE FOR YOU MADE FOR USE

Our products are made for everyday living spaces. Our collection is thoughtfully designed with high quality materials to meet the demands of a modern home.

To enjoy WOOD products for years to come, it is important to take care of them in the best possible way. Wood is one of our favourite materials but because it is a living material, it requires maintenance throughout its life span. We strive to create long-lasting original design with great attention to the material and its details. When we hand over our products, we hope you will give the design the attention it needs because great quality requires great care.

Take good care.



SKIRT TABLE DESIGNED BY MIKKO LAAKKONEN
ANNULAR PENDANT DESIGNED BY M-S-D-S





MONO CHAIR

SHAPE
MATERIAL
IDEA





KASPER NYMAN



The Finnish designer Kasper Nyman strives to challenge himself and the materials used in order to create products that comprehend modern Scandinavian design and visual simplicity.

The inspiration and idea behind the Mono chair came from a new innovative oak veneer. *"I wanted to design a concept, which made use of the new material's features. The wooden grain reacts to the overlapping construction of the seat and it lures you in to have a closer look at the detail"* says Kasper Nyman. Mono is an interpretation of the new possibilities the oak veneer provides as the overlapping construction of the seat would simply not be possible with conventional laminating techniques.



RACKET TRAY DESIGNED BY TERKEL SKOU STEFFENSEN
TAP AND TOP CANDLE HOLDER DESIGNED BY BETTE EKLUND

PAUSE DINING CHAIR AND TABLE DESIGNED BY KASPER NYMAN
LOOP TRAY DESIGNED BY JULIE TOLVANEN





PIDETSTALL FLOWERPOT DESIGNED BY EMILIE STAHL CARLSEN



MIRROR BOX

SCULPTURAL FUNCTIONALITY





LAURA BILDE

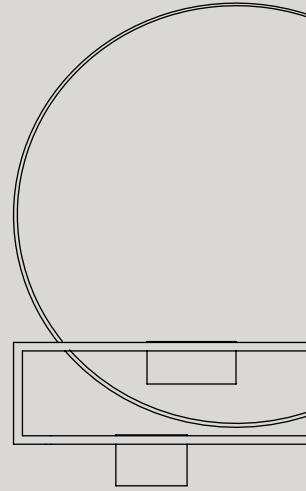

Laura Bilde is one of the most talented upcoming designers in Denmark at the moment. Her designs are characterised by the Scandinavian simplicity where aesthetics and functions are crossed in a sculptural universe. She manages to experiment with materials and simple details that bring joy into the use of her design.

Mirror Box is a great example of the characteristics of Laura Bilde's work because it is more than just a mirror. The steel frame construction fits four perforated storage boxes, a black marble plate and a circular mirror. With the graphic expression and minimalist design, Mirror Box works as a beautiful and functional decoration on the wall. Personalise it to suit your needs. Make it yours.



BARN CABINET DESIGNED BY SAYS WHO
GEM ORGANISER DESIGNED BY FRAII

DIAGONAL DINING TABLE AND BENCH DESIGNED BY SIGNE HYTTE
MONO DINING CHAIR DESIGNED BY KASPER NYMAN
HINKEN FLOWERPOT DESIGNED BY SILJE NESDAL AND ANN KRISTIN EINARSEN





COUPÉ SHELF DESIGNED BY POIAT
HINKEN FLOWERPOT DESIGNED BY SILJE NESDAL AND ANN KRISTIN EINARSEN



HAAK HOOKS DESIGNED BY RIKKE FROST

ANNULAR PENDANT

REUSE THE SHAPE
RETHINK THE LIGHT





M-S-D-S STUDIO

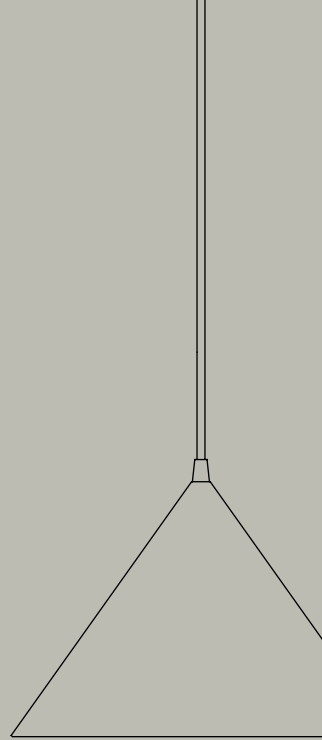

M-S-D-S Studio is a Toronto based multi-disciplinary design practice that works in interior, furniture, and product design. The studio is dedicated to material exploration and resourcefulness. M-S-D-S produces design that engages contemporary culture while adhering to the abiding principles of good design and the inheritance of craftsmanship.

The Annular pendant is a great example of M-S-D-S's design intelligence as the pendant pairs one primary form, a conical shade, with another, a perfect ring of light at the fixture's perimeter. Simple and quite brilliant. The light is designed to be evocative of classic pendant light fixtures and resolutely contemporary. M-S-D-S elegantly rethinks the light while reusing the shape of a classic cone pendant.

LEAN LOUNGE CHAIR DESIGNED BY NUR





COUPÉ SHELF DESIGNED BY POIAT
VIRKA SIDE BOARD DESIGNED BY RØPKE DESIGN AND MOAKK

VOWEL DESIGNED BY KEISUKE KAWASE





WALLIE DESIGNED BY AMALIE SKOV RAHBÆK

TÖJBOX

JUST PURE WOOD





MADE BY MICHAEL

Made by Michael is a design studio founded by Michael Daae Christensen with the aim of carrying on the Scandinavian design traditions of quality and long-lasting products. The characteristics of the studio are functionality and simplicity with a special awareness on sustainability. Made by Michael's preferred material is wood – as part of his approach to sustainability, Michael experiments with different joint methods while having a constant focus on production, manufacturing and packaging. The goal of the design by Made by Michael is to leave the viewer with a little 'Aha' moment of childish wonder and joy. Tøjbox is no exception. At first sight, the design provokes with its simple and light construction – but nothing about Tøjbox is random. It is the small details that give Tøjbox its character.



MIRROR BARB DESIGNED BY MARTIN ZANOLIN
WALLIE DESIGNED BY AMALIE SKOV RAHBÆK





DOT PENDANT DESIGNED BY RIKKE FROST
BUK CHAIR DESIGNED BY NUR AND LÆRKE BO POULSEN
COME HERE SIDE TABLE DESIGNED BY STEFFEN JUUL



NUNU ELEPHANT DESIGNED BY STEFFEN JUUL

HINKEN FLOWERPOT DESIGNED BY SILJE NESDAL AND ANN KRISTIN EINARSEN





POLAR SHELF DESIGNED BY TERHEDEBRÜGGE
STONE PENDANT DESIGNED BY PHILIP BRO



PIDESTALL FLOWERPOT DESIGNED BY EMILIE STAHL CARLSEN

STEDGE SHELF

UNBALANCED BALANCE





LEONARD ALDENHOFF

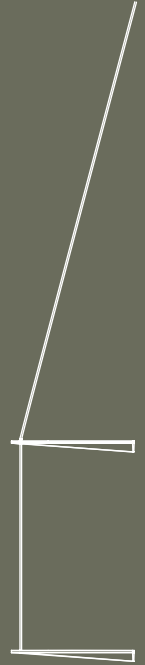

The talented German designer, Leonard Aldenhoff, combines industrial mechanic know-how with creativity and aesthetics. Inspired by technical and geometrical precision, his work is characterised by clear forms and meticulousness.

Stedge was created within the scope of a university project. The shelf should demonstrate lightness, purism and a clear structure. The subtle design functions as an optical illusion as the solid shelves seem to hang by a thread. The unbalanced appearance of the Stedge shelf makes it a minimalistic stage. The minimum usage of needed parts is used to establish a stable and modern shelf. The form of the shelf creates a delicate look because most of the time you only see the wide framed edge. Simple, elegant and carefully thought through.



AA DESK DESIGNED BY SPANT STUDIO
MONO DINING CHAIR DESIGNED BY KASPER NYMAN
COUPÉ SHELF DESIGNED BY POIAT
GEM ORGANISER DESIGNED BY FRAII



DIAGONAL BENCH DESIGNED BY SIGNE HYTE
STONE PENDANT DESIGNED BY PHILIP BRO
NUNU ELEPHANT DESIGNED BY STEFFEN JUUL
COME HERE SIDE TABLE DESIGNED BY STEFFEN JUUL
RAINING CIRCLE RUG DESIGNED BY RIKKE MALLING



POCKET MIRROR DESIGNED BY DANIEL SCHOFIELD



BAENK BENCH DESIGNED BY NUR

HONESTY

No need to make something more than it actually is. No need to come up with something that is not true. No need to hide something that needs to be seen. In our products, in our work and in our approach, honesty is paramount to us.

We believe that what you see is what you get. Our products' honesty is reflected in the material chosen. It should not look like something else. If looks and feels like wood, it is because it is. Turn it around. Look inside. It is honest and high quality all the way through.

RAINING CIRCLE RUG DESIGNED BY RIKKE MALLING
VIRKA SIDEBOARD DESIGNED BY RØPKE DESIGN AND MOAKK



MIRROR BARB DESIGNED BY MARTIN ZANOLIN



SIMPLICITY

Why make it more complicated when the simplicity in the design speaks for itself. Simplicity is anchored in us through the Scandinavian design heritage. It can be in shape, expression, story, function, colour or material. Often it is the combination.

For us, simple designs are more aesthetically pleasing. Simplicity is more accessible. We know simple when we see it, when we touch it, when we use it. We hope you do too.

LÆKKERHED

[ˈlæɡərheð]

The Danish word 'lækkerhed' cannot be translated directly into English. It is that feel, that smell, that sound, that surface, that packaging, that softness, that roughness, that styling and that material. All of these should ooze of 'lækkerhed'. It is in our work and our way of doing things.

Look for the small refinements.

Time and effort have been put into every little detail for you to get that feeling of 'lækkerhed'. We hope you will find the small details. They are made for you and made for use.

MERCURY WALL LAMP DESIGNED BY JEANETTE HOLDGAARD
VIRKA SIDEBORD DESIGNED BY RØPKE DESIGN AND MOAKK
TIP AND TOP CANDLE HOLDERS DESIGNED BY BETTE EKLUND





RACKET TRAY DESIGNED BY TERKEL SKOU STEFFENSEN

SPLIT DINING TABLE DESIGNED BY SAYS WHO
ANNULAR PENDANT DESIGNED BY M-S-D-S STUDIO



MONO DINING CHAIR DESIGNED BY KASPER NYMAN



INPUT ORGANISER DESIGNED BY ANNE HOLM AND SIGRID SMETANA

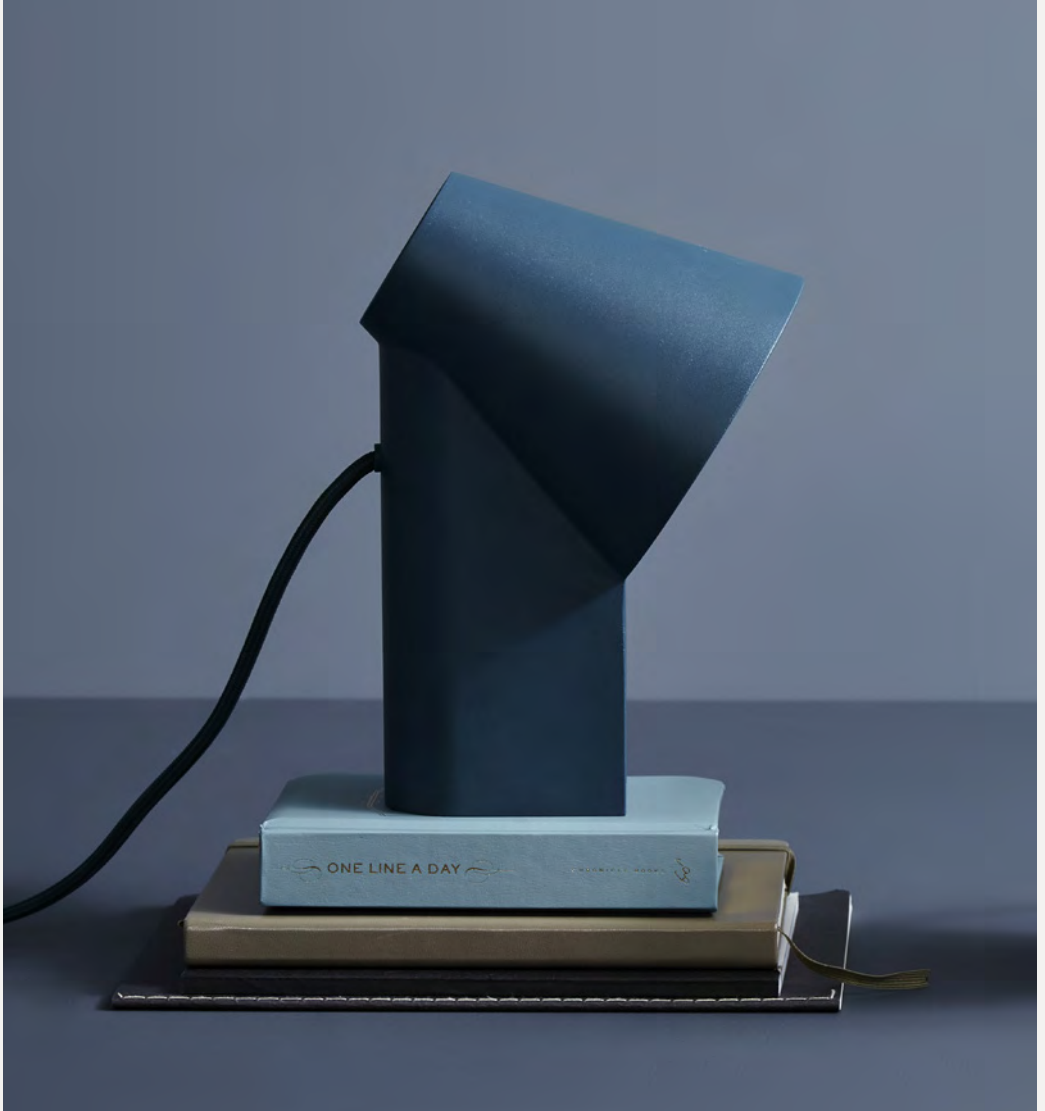

STUDY TABLE LAMP DESIGNED BY M-S-D-S STUDIO

WE WANT TO SHARE OUR LOVE FOR HONEST DESIGN WITH YOU

WOUD was founded with our love for honest design and we want to share that love with you. WOUD is the dream of founding a strong, ambitious design brand in collaboration with talented designers who have that Scandinavian feel and expression with an international touch in their designs. The idea was to create an entire WOUD universe - and here we are today. Looking at our collection, we are so proud that we have come this far. However, the good thing about great design is that it never ends. We always continue our search for new items, new ideas and new stories to tell. We find our drive in the exploration of innovative design whether it is in form, function or material. We hope you enjoyed the collection and you found items that were love at first sight for you. If there is anything we can do to assist you, we WOUD always love to say hello.

Warm regards,

Mia and Torben Koed

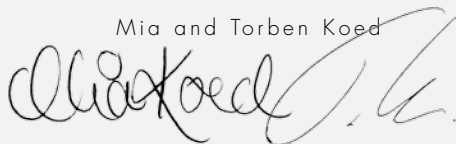
A handwritten signature in black ink, appearing to read 'Mia and Torben Koed', written in a cursive, flowing style.

MIA AND TORBEN KOED FOUNDERS OF WOULD





GEYMA SIDE BOARD DESIGNED BY NUR
STONE PENDANT DESIGNED BY PHILIP BRO
HINKEN FLOWERPOT DESIGNED BY SILJE NESDAL AND ANN KRISTIN EINARSEN

COLLECTION OVERVIEW

SEATING

64 - 73

SOFA

74 - 77

TABLES

78 - 86

STORAGE

87 - 91

SHELVING

92 - 99

LIGHTING

100 - 108

MIRRORS

109 - 113

ACCESSORIES

114 - 126

SEATING

PAUSE

MONO

S.A.C.

BUK

LEAN

BAENK

DIAGONAL



PAUSE DINING CHAIR

DESIGNED BY KASPER NYMAN

MATERIALS

Solid oak, plywood and oak veneer

DETAILED DESCRIPTION

Legs, apron and back are made of solid oak. The seat is made of plywood with oak veneer. Available in five colours.

Felt glides are included.

EN 12520:2010 (Domestic)

EN 1022:2005 (Domestic)

DIMENSIONS (MM)

L 480 x D 470 x H 800 / S-H 460

ITEM NO / COLOUR

100001 White pigmented lacquer oak

100002 Black painted oak

100003 Light blue painted oak

100004 Green painted oak

100005 Dark blue painted oak

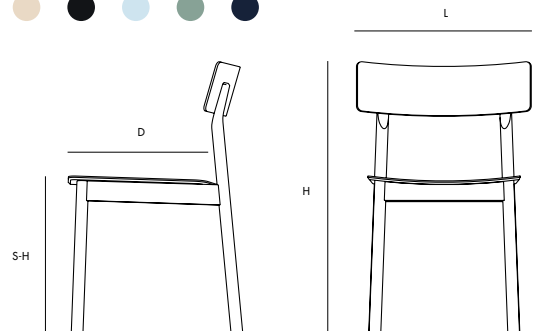



PAUSE BAR STOOL/COUNTER CHAIR

DESIGNED BY KASPER NYMAN

MATERIALS

Solid oak, plywood, oak veneer, brass

DETAILED DESCRIPTION

Legs, apron and back are made of solid oak. The seat is made of plywood with oak veneer. Footrest comes with untreated brass cover. Available in five colours.

Felt glides are included.

EN 12520:2010 (Domestic)

EN 1022:2005 (Domestic)

DIMENSIONS (MM)

BAR STOOL

L 457 x D 465 x H 953 / S-H 750

COUNTER CHAIR

L 457 x D 465 x H 853 / S-H 650

ITEM NO / COLOUR

100801 / 100901 White pigmented oak

100802 / 100902 Black painted oak

100803 / 100903 Light blue painted oak

100804 / 100904 Green painted oak

100805 / 100905 Dark blue painted oak

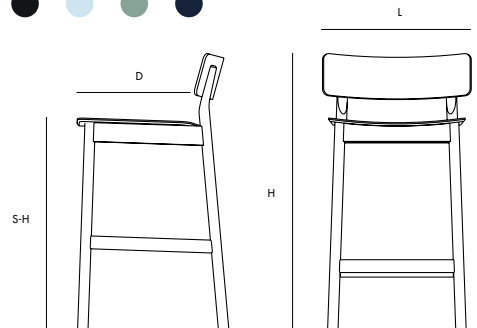



PAUSE SEAT PAD

DESIGNED BY KASPER NYMAN

MATERIALS

Gabriel Breeze Fusion fabric (88% Wools of New Zealand, 12% Polyamide) and anti-slip material.

DETAILED DESCRIPTION

Upholstered with Gabriel Breeze Fusion fabric for great durability. The seat pad is fitted with a layer of anti-slip material.

Upholstery specification

Martindale: 100.000

Piling: 4-5

DIMENSIONS (MM)

DINING SEAT PAD

L 410 x D 410 x H 6

BAR STOOL / COUNTER CHAIR SEAT PAD

L 409 x D 380 x H 6

ITEM NO / COLOUR

DINING / COUNTER & BAR STOOL

108030 / 108050 Breeze Fusion 4001 Grey

108031 / 108051 Breeze Fusion 4804 Green

108032 / 108052 Breeze Fusion 4602 Blue

108033 / 108053 Breeze Fusion 4102 Beige

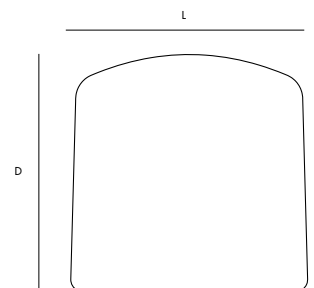



MONO DINING CHAIR

DESIGNED BY KASPER NYMAN

MATERIALS

Oak veneer, solid oak

DETAILED DESCRIPTION

The seat is made of plywood with oak veneer (UPM Grada). Legs and apron are made of solid oak. Available in oak and black painted oak.

Felt glides are included.

EN 1022:2005 (Domestic)

EN 16139:2013 (Non-domestic)

DIMENSIONS (MM)

L 450 x D 510 x H 780 / S-H 455

ITEM NO / COLOUR

100010 Wood care treated oak

100011 Black painted oak

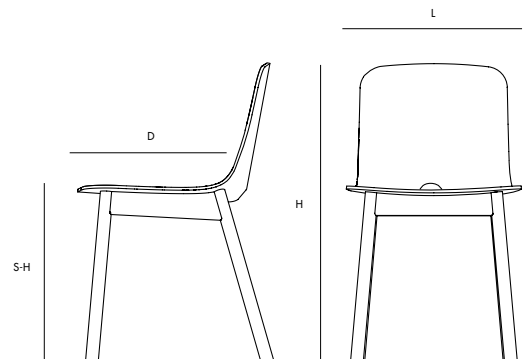



S.A.C. DINING CHAIR

DESIGNED BY NAOYA MATSUO

MATERIALS

Metal and oak veneered plywood

ITEM NO / COLOUR

100030 Black

DETAILED DESCRIPTION

Metal legs, apron and armrest. Seat and backrest in oak veneered plywood.

Felt glides are included.

EN 12520:2010 (Domestic)

EN 1728:2000 (Domestic)

EN 1022:2005 (Domestic)

DIMENSIONS (MM)

L 450 x S-D 510 / T-D 420 x H 780
/ S-H 455

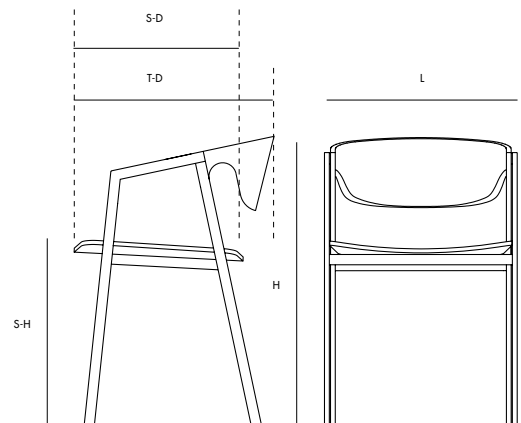



BUK CHAIR

DESIGNED BY LÆRKE BO POULSEN AND MAJA BØGH VINDBJERG

MATERIALS

Metal

DETAILED DESCRIPTION

The seat is made of one piece of metal. Legs are welded on to the apron and seat. The seat and legs are fully painted.

Made and assembled in Denmark.

DIMENSIONS (MM)

L 510 x D 515 x H 760 / S-H 465

ITEM NO / COLOUR

100050 Black

100051 White

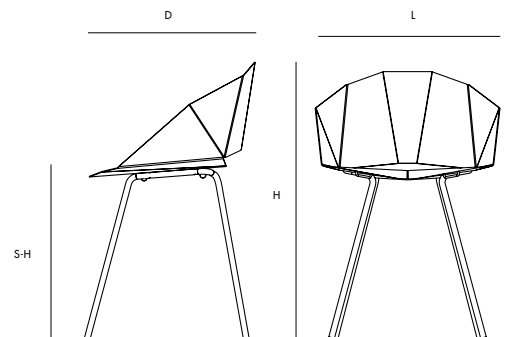



LEAN LOUNGE CHAIR

DESIGNED BY NUR

MATERIALS

Metal, plywood, Luna 2 or Remix 2

DETAILED DESCRIPTION

The seat and back have fibre padding and foam 35 kg/m³. The frame is plywood and powder coated metal.

Upholstery specification:

Gabriel Luna 2: 90% Wools of New Zealand, 10% polyamide. Martindale: 70.000

Kvadrat Remix 2: 90% New wool worsted, 10% nylon. Martindale: 100.000

DIMENSIONS (MM)

L 640 x D 660 x H 720 / S-H 360-380

ITEM NO / COLOUR

100710 Remix 2, 123 Grey

100711 Remix 2, 873 Dark blue

100712 Luna 2, 2393-4204 Mustard yellow

100713 Remix 2, 933 Green

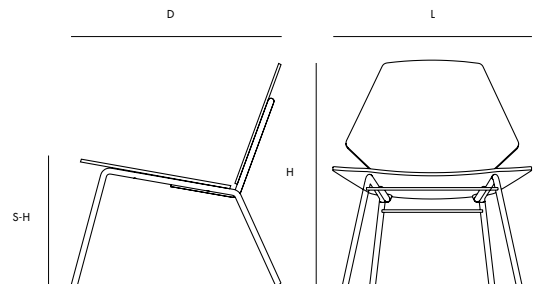



BAENK BENCH

DESIGNED BY NUR

MATERIALS

Oak, upholstery

DETAILED DESCRIPTION

Baenk has solid soap treated oak/oil treated smoked oak legs and top.

The fixed seat cushion is upholstered with Gabriel Breeze Fusion 4002 (Comp.: 88% Wools of New Zealand, 12% Polyamide, Martindale: 100.000) / Gabriel Medley 61004 (Comp.: 100% Polyester, Martindale: 75.000)

DIMENSIONS (MM)

L 1100 x D 425 x H 450

ITEM NO / COLOUR

101008 Soap treated oak
Gabriel Breeze Fusion 4002

101009 Oil treated smoked oak
Gabriel Medley 61004

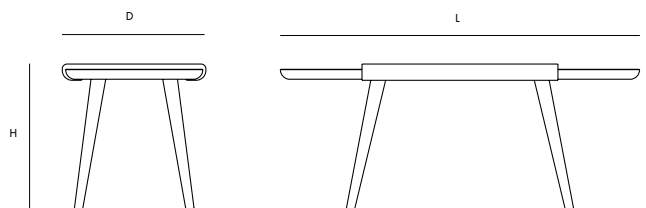



DIAGONAL BENCH

DESIGNED BY SIGNE HYTE

MATERIALS

Metal and oak veneered MDF

DETAILED DESCRIPTION

Diagonal bench has a metal tube frame with a oak veneered MDF top. Legs and frame are powder coated with a soft finish.

Tools are included.

DIMENSIONS (MM)

L 1600 x D 350 x H 450

ITEM NO / COLOUR

101001 Midnight blue

101002 Black

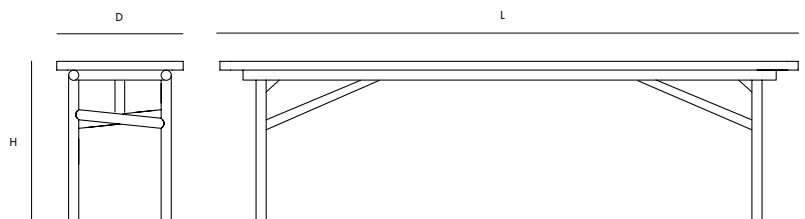

SOFAS

NAKKI SERIES

DESIGNED BY MIKA TOLVANEN

Our Nakki series is made of a strong wooden frame with the right amount of foam and webbing to make Nakki a comfortable and soft seating experience. Nakki is available in five price groups according to the fabric chosen. Choose between Gabriel or Kvadrat textiles and CAMO leather. Nakki is available in a soft version, which is suitable for domestic use and a firm version, which is suitable for contract use. It is possible to purchase customised cushions in five price groups to match the Nakki sofa.

UPHOLSTERY AVAILABLE

PRICE GROUP 1

Gabriel Step Melange

Martindale: 100,000. Composition: 100% Trevira cs

PRICE GROUP 2

Kvadrat Remix 2

Martindale: 100.000. Composition: 90% New wool worsted, 10% Nylon

Gabriel Luna 2

Martindale: 70,000. Composition: 90% Wools of New Zealand, 10% Polyamide

PRICE GROUP 3

Kvadrat Rime

Martindale: 100.000. Composition: 90% New wool worsted, 10% Nylon

PRICE GROUP 4

Kvadrat Steelcut Trio 2

Martindale: 100.000. Composition: 90% New wool worsted, 10% Nylon

Kvadrat Hallingdal

Martindale: 100.000. Composition: 70% New wool, 30% Viscose

Kvadrat Harald 2

Martindale: 100.000. Composition: 100 % Cotton

PRICE GROUP 5

CAMO Leathers: Silk Aniline

Grain leather from European cattle hides

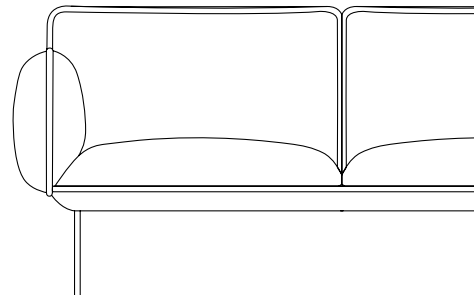



NAKKI SERIES

DESIGNED BY MIKA TOLVANEN

DIMENSIONS (MM)

TWO-SEATER

L 1800 x D 780 x H 830 / S-H 455

ONE-SEATER

L 970 x D 780 x H 830 / S-H 455

OTTOMAN

L 800 x D 800 x H 480

ITEM NO / COLOUR

NAKKI TWO-SEATER

107170 Price group 1
107171 Price group 2
107172 Price group 3
107173 Price group 4
107174 Price group 5

NAKKI ONE-SEATER

107190 Price group 1
107191 Price group 2
107192 Price group 3
107193 Price group 4
107194 Price group 5

NAKKI OTTOMAN

107200 Price group 1
107201 Price group 2
107202 Price group 3
107203 Price group 4
107204 Price group 5

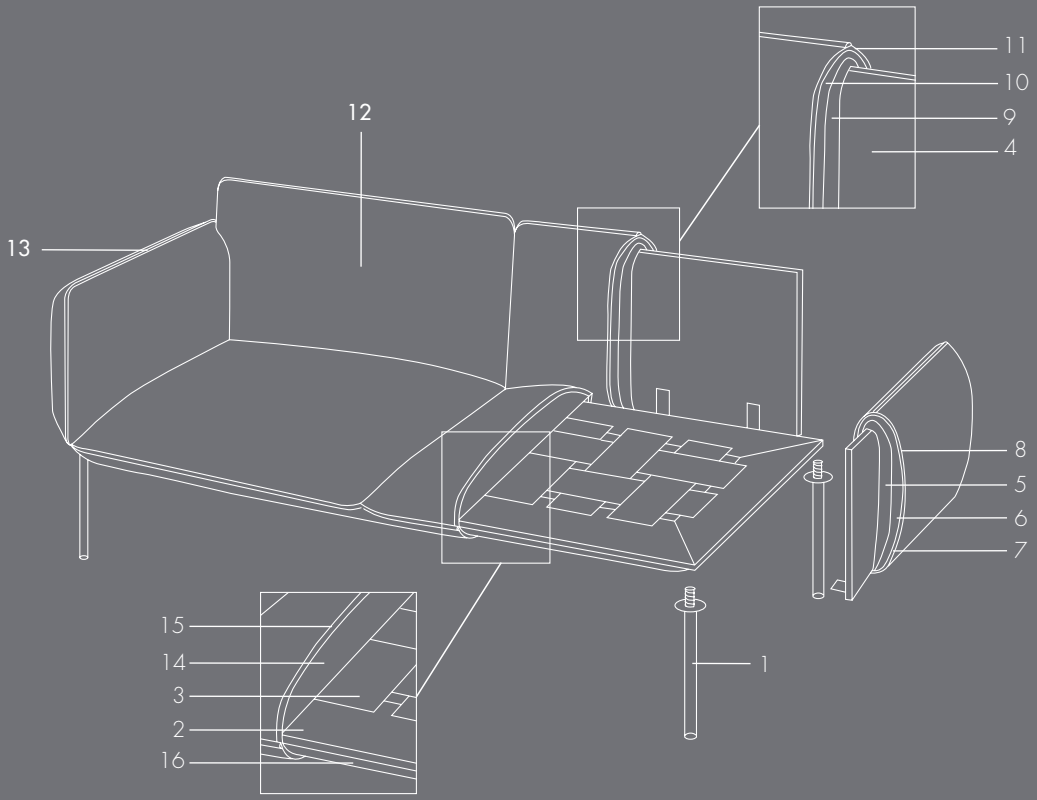
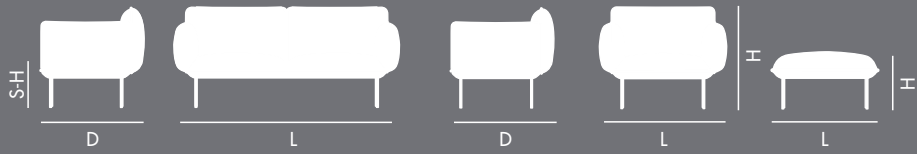

MATERIALS

- 1: Metal legs
- 2: Plywood
- 3: Elastic belts
- 4: Plywood
- 5: Foam 25-50
- 6: Foam 25-20
- 7: Foam 30-25
- 8: Webbing 100 g/m²
- 9: Foam 25-50
- 10: Foam 25-20
- 11: Foam 30-25
- 12: Fabric
- 13: Pipping 10 mm
- 14: Foam 35-50 (firm), 35-20 (soft)
- 15: Webbing 400 g/m²
- 16: Wooden frame

Fire retardant foam available

TABLES

DIAGONAL

SPLIT

PAUSE

AA DESK

SKIRT

SOROUND

COME HERE



DIAGONAL TABLE

DESIGNED BY SIGNE HYTE

MATERIALS

Metal and oak veneered MDF

DETAILED DESCRIPTION

Diagonal has a metal tube frame with a oak veneered MDF top. Legs and frame are powder coated with a soft finish.

Tools are included.

DIMENSIONS (MM)

L 1800 x W 900 x H 740

ITEM NO / COLOUR

110140 Midnight blue

110141 Black

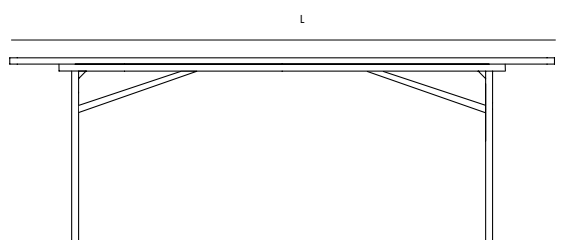
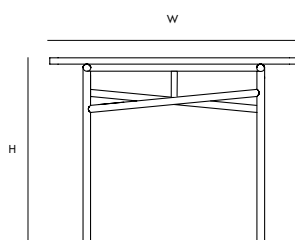



SPLIT DINING TABLE

DESIGNED BY SAYS WHO

MATERIALS

Solid oak, solid ash and metal

DETAILED DESCRIPTION

Legs are made of solid soap treated oak/ white painted ash/black painted ash. All with powder coated metal crossbar. The table top is made of solid soap treated North European oak/solid North European smoked oak with oil treatment. Felt glides and tools are included.

ITEM NO / COLOUR

- 110120 Top soap treated oak
Legs soap treated oak
- 110121 Top soap treated oak
Legs white painted ash
- 110122 Top soap treated oak
Legs black painted ash
- 110123 Top oil treated smoked oak
Legs black painted ash

DIMENSIONS (MM)

L 2050 x W 950 x H 740

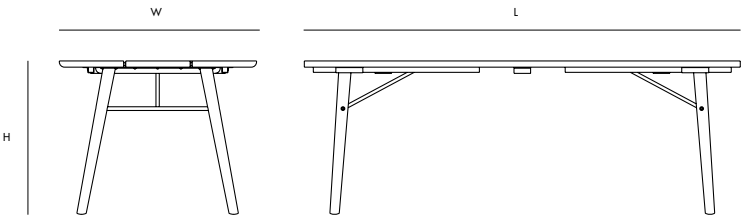



SPLIT TABLE EXTENSIONS

DESIGNED BY SAYS WHO

MATERIALS

Solid oak / MDF

DETAILED DESCRIPTION

Split table extensions are available in solid smoke and oil treated North European oak/soap treated North European oak/black painted MDF.

Tools are included.

SALES UNIT

Split table extensions are sold in sets of two.

DIMENSIONS (MM)

L 500 x W 900

ITEM NO / COLOUR

110124 Oil treated smoked oak

110125 Soap treated oak

110126 Black painted MDF

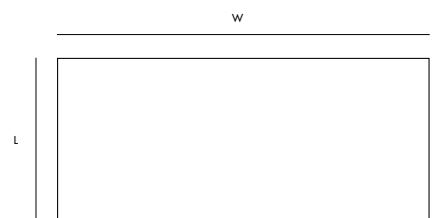



PAUSE DINING TABLE

DESIGNED BY KASPER NYMAN

MATERIALS

Solid oak, oak veneer and black linoleum

DETAILED DESCRIPTION

Legs and apron are made of solid soap treated oak. Table top is with oak veneered edges and black linoleum on top.

Felt glides and tools are included.

DIMENSIONS (MM)

L 2000 x W 850 x H 720

ITEM NO / COLOUR

110101 Black

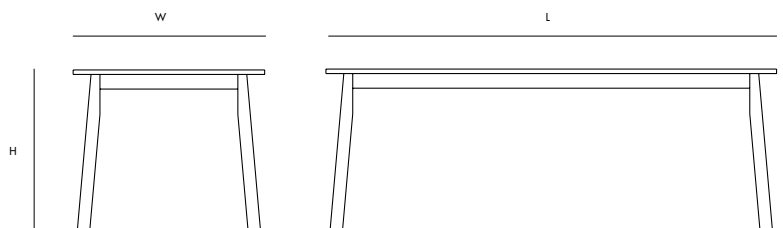



AA DESK

DESIGNED BY SPANT STUDIO

MATERIALS

Oak, metal, plywood, linoleum and LED light

DETAILED DESCRIPTION

Legs are made of solid soap treated oak with powder coated metal stabilisers. The shelf and table top are made of plywood with black linoleum. Black painted solid wood light beam with integrated LED light (1300 kelvin/900 lumen).

AA Desk comes with an open metal box for placing a power outlet.

Power outlet is not included.

DIMENSIONS (MM)

L 1520 x W 750 x H 1520

ITEM NO / COLOUR

110810 Oak/black

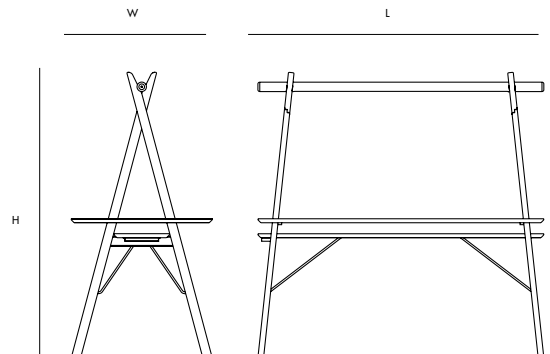



SKIRT COFFEE TABLE

DESIGNED BY MIKKO LAAKKONEN

MATERIALS

Solid oak and oak veneered plywood

DETAILED DESCRIPTION

Legs are solid oak. Table top and sides are made in oak veneered plywood. Available with either white pigmented lacquer treatment or black painted oak.

DIMENSIONS (MM)

HIGH: H 440 X Ø 400

LOW: H 380 x Ø 600

ITEM NO / COLOUR

110501 Matt white pigmented lacquer (High)

110502 Black (High)

110510 Matt white pigmented lacquer (Low)

110511 Black (Low)

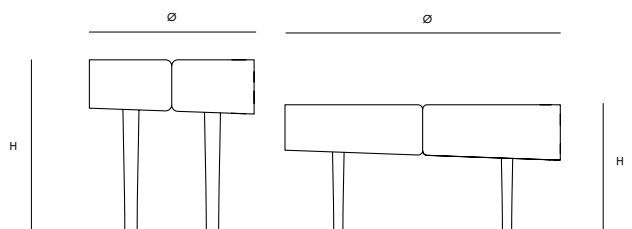



SOROUND SIDE TABLE

DESIGNED BY NUR

MATERIALS

Plywood or fibre concrete, metal

DETAILED DESCRIPTION

The table tops for Soround are available in two versions. In plywood (Ø 600mm & 750 mm) with Arpa Fenix NTM laminate and exposed plywood edges with matt lacquer or in solid fibre concrete (Ø 600 mm).

The table legs are powder coated metal.

Concrete is a natural material therefore not two tabletops will be alike. The Fenix laminate has an ultra matt soft touch surface with low light reflectivity. It is resistant to scratches and abrasion and easy to clean.

DIMENSIONS (MM)

Concrete: H 440 x Ø 600 / H 395 x Ø 600
Fenix: H 395 x Ø 600 / H 440 x Ø 750

ITEM NO / COLOUR

- 110519 Concrete top (Ø 60 cm, H 44 cm)
- 110520 Concrete top (Ø 60 cm, H 39,5 cm)
- 110521 Fenix top (Ø 60 cm, H 39,5 cm)
- 110526 Fenix top (Ø 75 cm, H 44 cm)

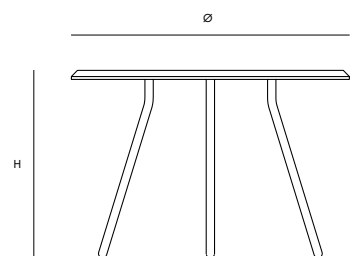



COME HERE SIDE TABLE

DESIGNED BY STEFFEN JUUL

MATERIALS

Oak

DETAILED DESCRIPTION

Come Here is made in solid Northern European oak. Choose between soap treated, oil treated smoked oak and painted oak.

DIMENSIONS (MM)

H 450 x Ø 410

ITEM NO / COLOUR

- 110710 Soap treated oak
- 110711 Black painted oak
- 110712 Light blue painted oak

- 110713 Midnight blue painted oak
- 110714 Green painted oak
- 110715 Yellow painted oak
- 110716 Oil treated smoked oak

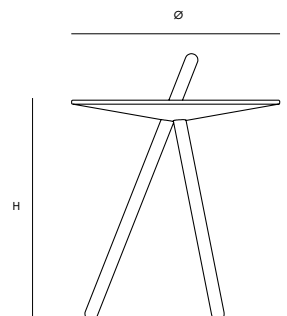

STORAGE

TÖJBOX

BARN

GEYMA

VIRKA



TÖJBOX WARDROBE

DESIGNED BY MADE BY MICHAEL

MATERIALS

Veneered plywood, oak.

DETAILED DESCRIPTION

The top box is made from oak veneered plywood. The rest is North European oak in either wood care treated or black painted oak. On the back of the top box are two keyhole mountings to secure a fixed wall hanging.

Screws are included.

DIMENSIONS (MM)

LARGE: L 1120 X D 380 X H 2000

SMALL: L 800 x D 300 x H 2000

ITEM NO / COLOUR

120200 Wood care treated oak (Large)

120201 Black painted oak (Large)

120220 Wood care treated oak (Small)

120223 Black painted oak (Small)

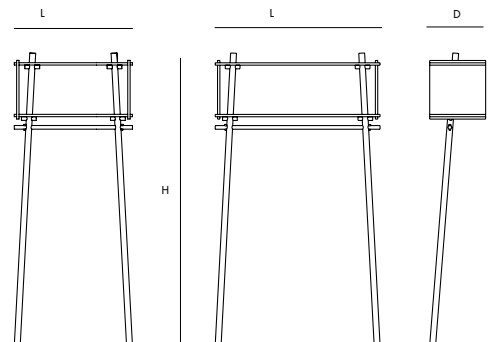

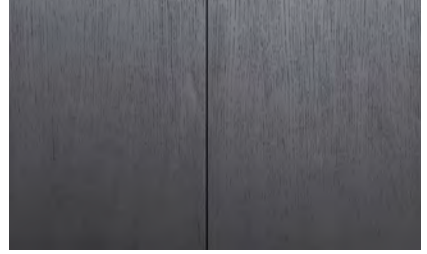

BARN CABINET

DESIGNED BY SAYS WHO

MATERIALS

Oak veneered MDF, metal

DETAILED DESCRIPTION

Carcass and doors are fully oak veneered MDF. The six, light grey oak veneered shelves inside offer neat storage together with two perforated metal boxes with fabric covered bottoms.

Legs are made of powder coated metal. The metal legs have adjustable feet to adjust the level of the cabinet.

DIMENSIONS (MM)

L 1000 x D 430 x H 1500

ITEM NO / COLOUR

120510 Black painted oak

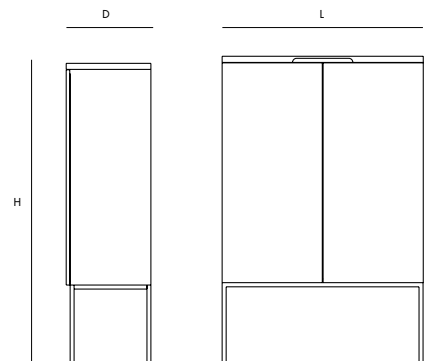



GEYMA SIDEBOARD

DESIGNED BY NUR

MATERIALS

Oak veneered plywood, laminate, metal

DETAILED DESCRIPTION

Carcass is made from black painted oak veneered plywood with visible matt laquered edges. Doors are made of plywood with grey and light grey laminate.

Legs are powder coated metal.

In the backboard of the sideboard are two circular shaped cable holes for easy cable routing.

DIMENSIONS (MM)

HIGH: L 1200 X D 475 X H 710

LOW: L 1400 X D 420 X H 420

ITEM NO / COLOUR

120300 Black/grey (High)

120400 Black/grey (Low)

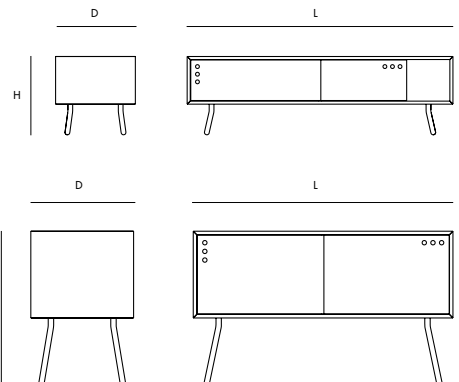



VIRKA SIDEBOARD

DESIGNED BY RØPKE DESIGN AND MOAKK

MATERIALS

Oak veneered plywood

DETAILED DESCRIPTION

Carcass and doors are made from oak veneered plywood. Black painted oak veneer/soap treated oak veneer carcass with black painted oak veneer/soap treated oak doors. Virka (high) comes with one shelf in each side, circular shaped cable holes in the backboard for easy cable routing. The leg frame is black powder coated metal. The leg frame is detachable and has adjustable feet to adjust the level of the sideboard.

DIMENSIONS (MM)

HIGH: L 1200 X D 400 X H 820

LOW: L 1200 x D 400 x H 470

ITEM NO / COLOUR

120310 Black/oak (High)

120311 Oak/oak (High)

120410 Black/oak (Low)

120411 Oak/oak (Low)

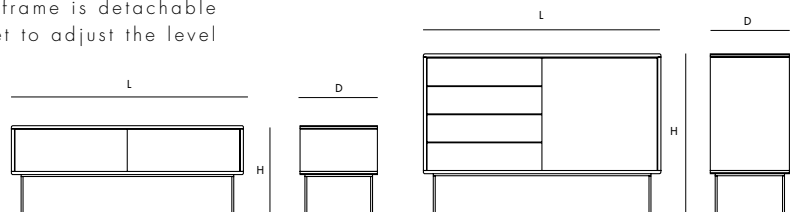

SHELVING

STEDGE

COUPÉ

FOLD

POLAR

VOWEL

WALLIE

INPUT

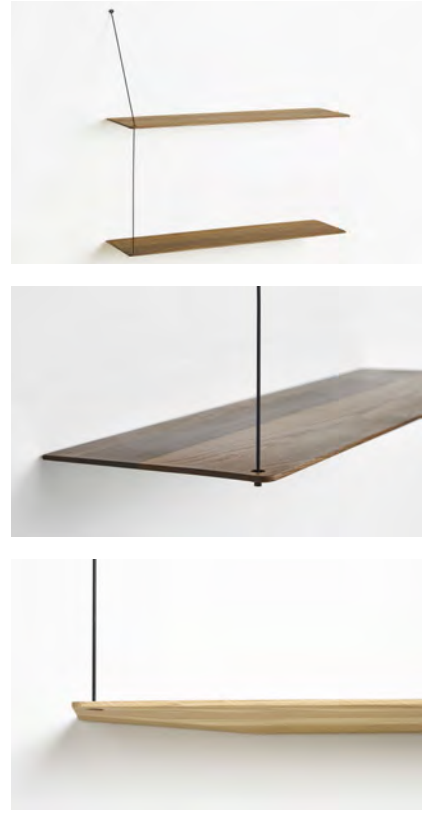

STEDGE SHELF

DESIGNED BY LEONARD ALDENHOFF

MATERIALS

Oak, metal

DETAILED DESCRIPTION

The shelf boards measure 20 mm at its thickest point and 4 mm at its thinnest. Max 10 kg weight on each shelf board. Black coated metal wire and fitting bolts. Stedge comes with a mounting template for easy instalment. The Stedge shelving system can be extended with as many shelves as you like. Included is a short and long top wire. The space between the shelves is 400 mm.

Screws are included.
Wall plugs are not included.

DIMENSIONS (MM)

SHELF: L 800 X D 220 X H 1200 / 770
ADD ON SHELF: L 800 x D 220 x H 400

ITEM NO / COLOUR

- 140012 White pigmented matt lacquer
- 140013 Oil treated smoked oak
- 140020 Add on shelf (White pigmented)
- 140023 Add on shelf (Smoked oak)

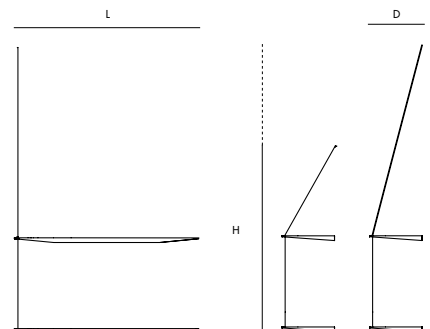

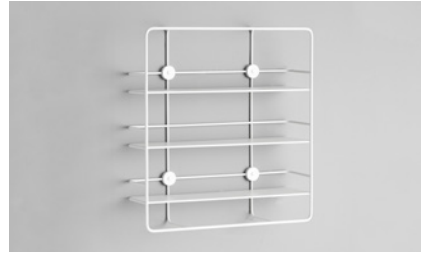
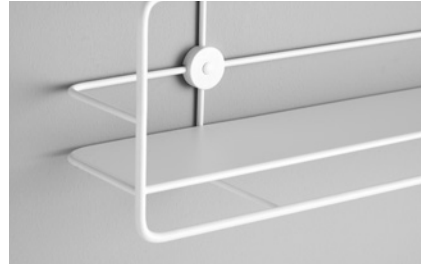

COUPÉ SHELVES

DESIGNED BY POIAT

MATERIALS

Metal

DETAILED DESCRIPTION

Soft matt powder coated metal.

Screws are included.

Wall plugs are not included.

DIMENSIONS (MM)

HORIZONTAL L 900 X D 135 X H 210

VERTICAL L 370 X D 135 X H 1030

RECTANGULAR L 530 X D 135 X H 560

ITEM NO / COLOUR

140120 Black horizontal

140121 White horizontal

140130 Black vertical

140131 White vertical

140140 Black rectangular

140141 White rectangular

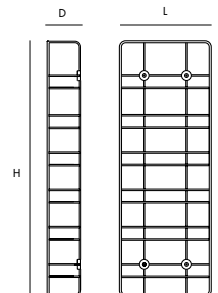
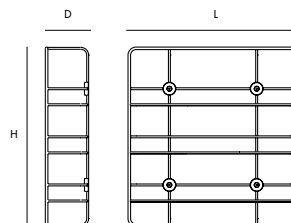
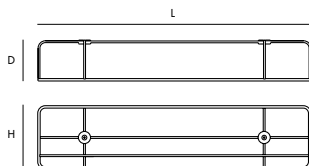

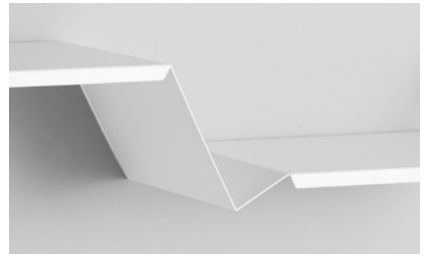
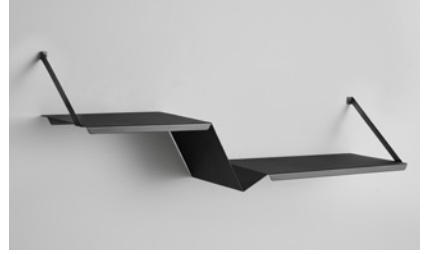

FOLD SHELF

DESIGNED BY NUR

MATERIALS

Metal

DETAILED DESCRIPTION

Fold shelf is made of soft matt powder coated metal. Available in black or white painted metal.

Screws are included.
Wall plugs are not included.

Max. weight 10 kg

DIMENSIONS (MM)

L 862 x D 225 x H 295

ITEM NO / COLOUR

140110 Black

140111 White

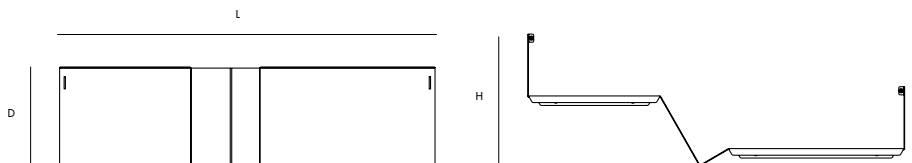



POLAR SHELF

DESIGNED BY TERHEDEBRÜGGE

MATERIALS

Metal

DETAILED DESCRIPTION

Polar shelf is made from painted metal. The frame can be turned upside down for the metal loop to be placed either to the left or to the right.

Screws are included.
Wall plugs are not included.
Max. weight 5 kg.

DIMENSIONS (MM)

L 446 x D 203 x H 196

ITEM NO / COLOUR

140165 Deep red

140166 Dusty grey

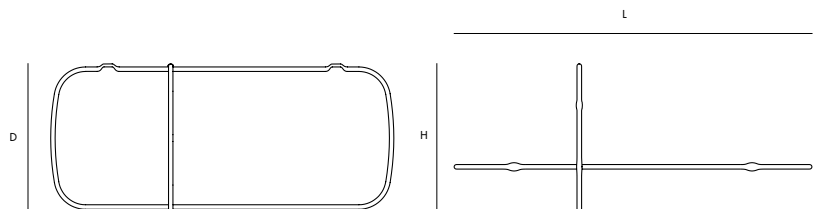

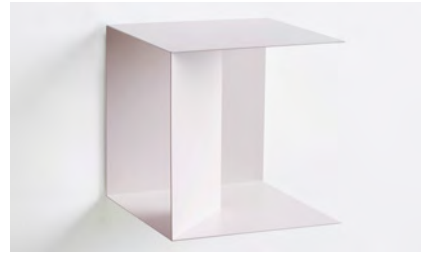
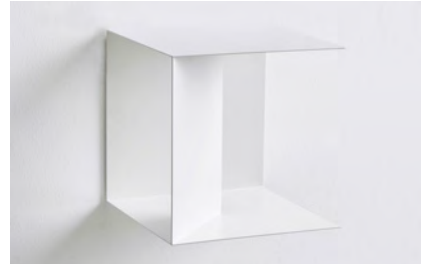

VOWEL SHELF

DESIGNED BY KEISUKE KAWASE

MATERIALS

Metal

DETAILED DESCRIPTION

Vowel is a powder coated metal wall unit. Available in four colours (red, nude and blue: 18-25% gloss, white: 30-40% gloss).

The wall mounting makes it possible to turn Vowel two ways in order for the divider to be placed to the left or to the right.

Screws are included
Wall plugs are not included.

DIMENSIONS (MM)

L 230 x D 235 x H 230

ITEM NO / COLOUR

140180 White

140181 Blue

140182 Red

140183 Nude

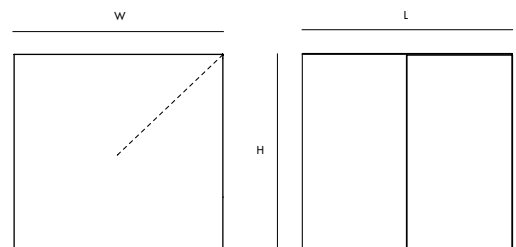



WALLIE SHELF DRAWER

DESIGNED BY AMALIE SKOV RAHBÆK

MATERIALS

Metal, oak

DIMENSIONS (MM)

L 300 x D 225 x H 100

DETAILED DESCRIPTION

Wallie is made from soft matt powder coated metal bracket and a bended oak veneer with white lacquer treatment drawer.

The wood drawer has a magnet encased on the backside for it to easily capture the metal bracket.

Screws are included.
Wall plugs are not included.

Max. weight 5 kg.

ITEM NO / COLOUR

140170 Oak / Black

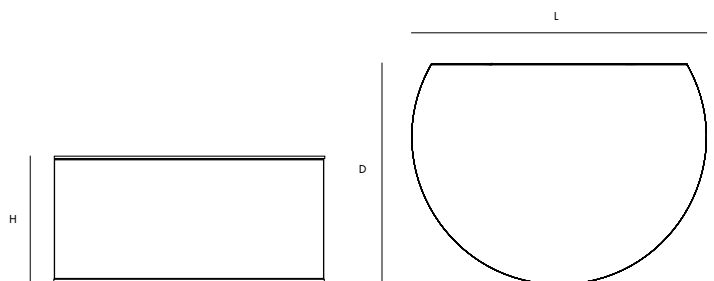



INPUT ORGANISER

DESIGNED BY ANNE HOLM AND SIGRID SMETANA

MATERIALS

Oak

DIMENSIONS (MM)

L 660 x D 65 x H 440

DETAILED DESCRIPTION

Input organiser is made from untreated solid oak and comes with eight sliding oak pockets.

ITEM NO / COLOUR

140160 Oak

Screws are included.
Wall plugs are not included.

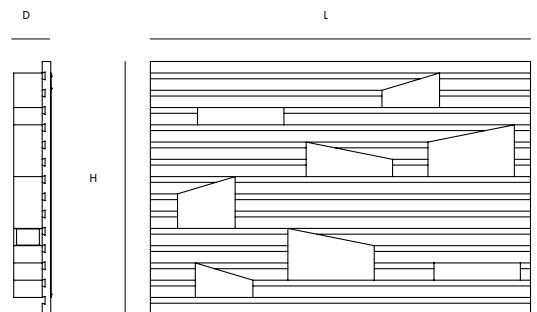

LIGHTING

GAP

DOT

STONE

LADDER LIGHT

ANNULAR

STUDY

BENSHEE

MERCURY

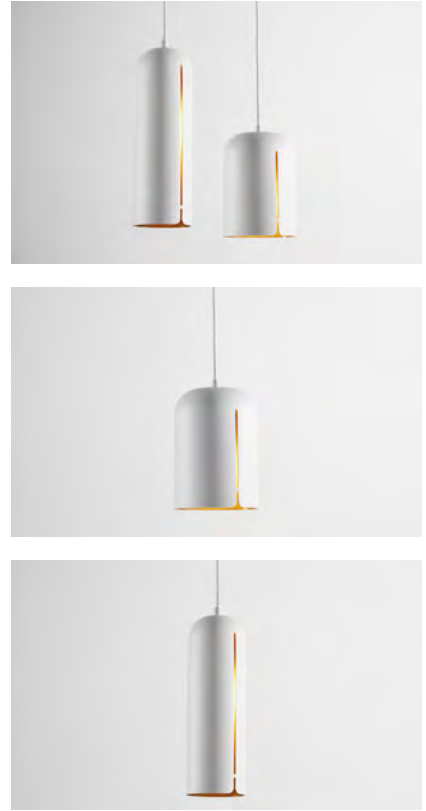

GAP PENDANT

DESIGNED BY NUR

MATERIALS

Powder coated metal with rough surface

DETAILED DESCRIPTION

Black and white powder coated metal with brass colour paint inside. 300 cm fabric covered cord with a black or white metal canopy (Ø 13 x H 5 cm).

Socket E27 max 25W/250lm.

All light source types applicable.

Energy label A++.

Complies with IP20. 220-240V.

CE, CB certifications.

Bulb is not included.

DIMENSIONS (MM)

SHORT: H 200 X Ø 140

TALL: H 300 X Ø 100

ITEM NO / COLOUR

133001 Black short

133002 Black tall

133003 White short

133004 White tall

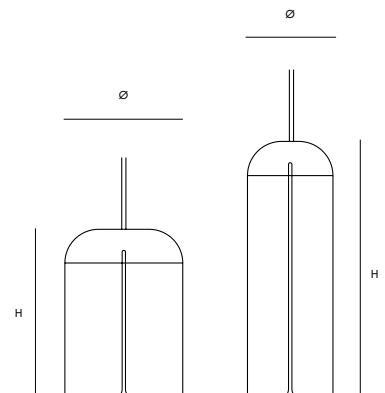



DOT PENDANT

DESIGNED BY RIKKE FROST

MATERIALS

Metal, opal glass

DETAILED DESCRIPTION

Dot consists of a perforated metal cup with an opal glass bottom. The glass bottom can be screwed off for easy access to the light source. Comes with 300 cm fabric covered cord and a black or white metal canopy (Ø 13 x H 5 cm). Socket E14 max 25W/250lm. All light source types applicable. Energy label A++. Complies with IP20. 220-240V. CE, CB certifications. Bulb is not included.

DIMENSIONS (MM)

S: H 130 x Ø 120

M: H 166 x Ø 120

L: H 210 x Ø 120

ITEM NO / COLOUR

133010 Black S

133011 Black M

133012 Black L

133013 White S

133014 White M

133015 White L

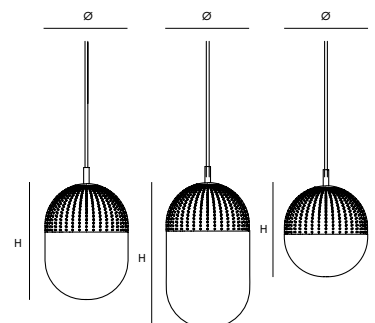



STONE PENDANT

DESIGNED BY PHILIP BRO

MATERIALS

Metal

DETAILED DESCRIPTION

Stone consists of two painted metal shades with a smooth surface. The 300 cm cord is fabric covered in either black, white or grey. The canopy is either black or white coloured metal (Ø 13 x H 5 cm).

Large: Socket E27

Small: Socket E14

Max 25W/250lm. All light source types applicable. Energy label A++.

Complies with IP20. 220-240V.

CE, CB certifications.

Bulb is not included.

DIMENSIONS (MM)

L: H 360 x Ø 358

S: H 160 x Ø 159

ITEM NO / COLOUR

133020 Grey L

133021 Black L

133022 White S

133023 Grey S

133024 Black S

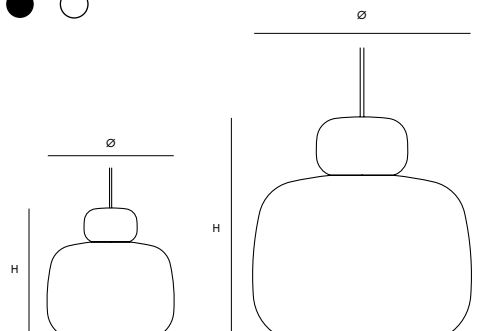

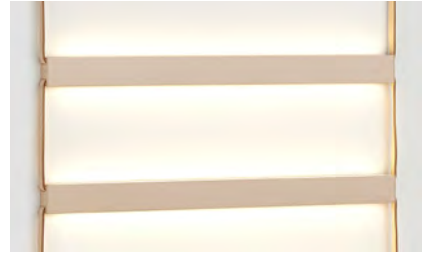

LADDER LIGHT 3/5

DESIGNED BY M-S-D-S STUDIO

MATERIALS

Leather, aluminum, acryl

DETAILED DESCRIPTION

Ladder Light consists of leather straps with internal wire routing and aluminum bars with LED on both sides.

Ladder 3: 6 strips max 12,6W

Ladder 5: 10 strips max 17W

White 200 cm PVC cord.

2800 Kelvin. 1000lm/LED stripe.

Energy label A++. 220-240V.

Complies with IP20.

CE, WEE certifications.

Ladder light can be dimmed on the on/off button and comes with a power adapter.

EU plug.

Bulb is build in (30.000 hours lifetime).

DIMENSIONS (MM)

LADDER LIGHT 3: H 800 x W 616

LADDER LIGHT 5: H 1219 x Ø 159

ITEM NO / COLOUR

130010 Ladder 3

130011 Ladder 5

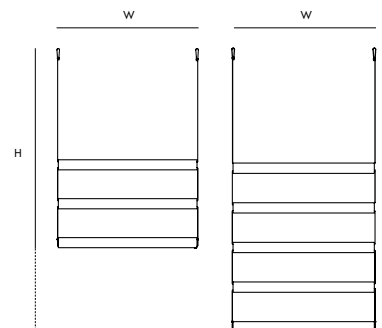



ANNULAR PENDANT

DESIGNED BY M-S-D-S STUDIO

MATERIALS

Aluminum

DETAILED DESCRIPTION

Annular is powder coated aluminum with a fine texture. Fabric covered cord (300 cm) with a black or white plastic canopy (H 7,5 x Ø 11 cm). 12W LED integral driver in the shade. 2800 Kelvin. 1500 lumen.

Energy label A++.

Complies with IP20.

220-240V.

CE certification.

Bulb is build in (30.000 hours lifetime).
LED and driver not replacable.

DIMENSIONS (MM)

H 238 x Ø 320

ITEM NO / COLOUR

133030 White

133031 Nude

133032 Mint

133033 Black

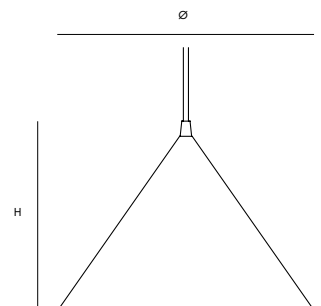



STUDY TABLE LAMP

DESIGNED BY M-S-D-S STUDIO

MATERIALS

Aluminum

DETAILED DESCRIPTION

Study is made from painted aluminum with a smooth texture. Comes with either a blue or white 210 cm fabric covered cord with the on/off switch 51 cm from the base. Socket E27, LED max 8W/450lm.

All light source types applicable. Energy label A++.

Complies with IP20. 220-240V.

CE certification.

EU plug.

0,5W LED bulb is included.

DIMENSIONS (MM)

L 159 x D 134 x H 227

ITEM NO / COLOUR

137010 Petrol blue

137011 White

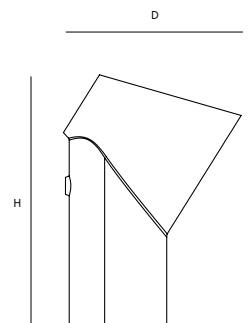



BENSHEE TABLE LAMP

DESIGNED BY JANNIS ELLENBERGER

MATERIALS

Metal

DETAILED DESCRIPTION

Benshee is made from painted sheet metal with a smooth texture. Comes with white, black, grey or yellow fabric covered cord (170 cm) with on/off switch 18 cm from the base. 12 LED 0,5W. Energy label A++. Complies with IP20. 220-240V. CE certification.

EU plug.
12 x 0,5W LED bulb is build in.
30.000 hours lifetime.
LED is not replaceable.
K14-12C500 is replaceable.

DIMENSIONS (MM)

L 304 x D 140 x H 266

ITEM NO / COLOUR

137001 Black

137002 White

137003 Grey

137004 Yellow

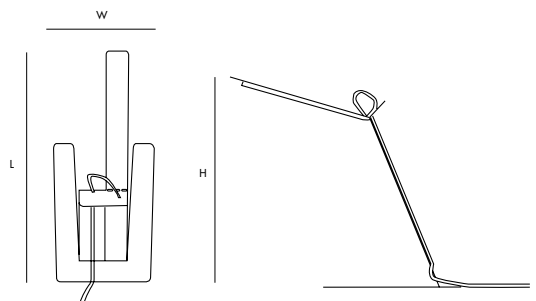



MERCURY WALL LAMP

DESIGNED BY JEANETTE HOLDGAARD

MATERIALS

Metal

DETAILED DESCRIPTION

Mercury is black powder coated metal with a rough texture. 210 cm black fabric covered cord with EU plug. 18 W LED light build ind. Dimmer on the shade.

Kelvin 3000-3100K
Lumen 120-130lm/l W
RA-index > 80
100-240V

Screws are included.
Wall plugs are not included.

DIMENSIONS (MM)

L 1097 x D 92 x H 1521 x Ø 300

ITEM NO / COLOUR

137005 Black

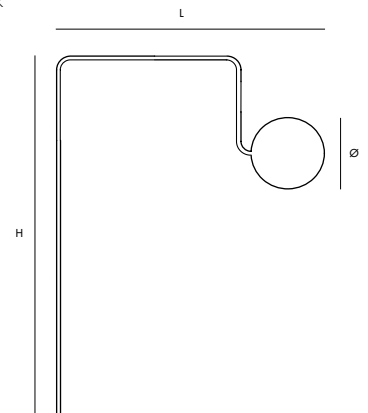

MIRRORS

MIRROR BOX

MIRROR BARB

TIME WATCH

POCKET MIRROR



MIRROR BOX

DESIGNED BY LAURA BILDE

MATERIALS

Metal, mirror glas, marble

DETAILED DESCRIPTION

The Mirror Box frame is black powder coated metal. Comes with four perforated painted metal boxes and a black marble plate (L 150mm x W 103mm x H 15mm).

The mirror (Ø 500mm, D 4mm) is safety glass and the mirror can be placed either to the left or to the right on the metal frame.

Screws are included.
Wall plugs are not included.

DIMENSIONS (MM)

H 750 x L 750 x D 120 x Ø 500

ITEM NO / COLOUR

140150 Black

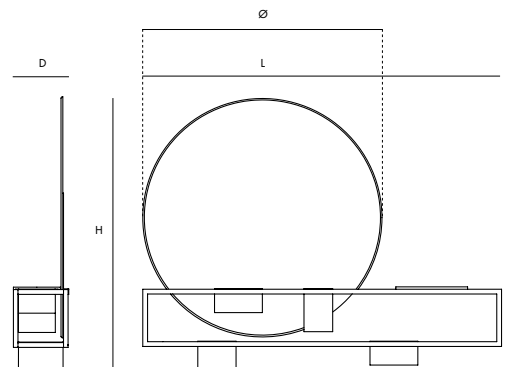



MIRROR BARB

DESIGNED BY MARTIN ZANOLIN

MATERIALS

Oak, mirror glass

DETAILED DESCRIPTION

Mirror Barb consists of solid oak with a safety mirror glass with bevel edges. Comes with an attachable oak handle and a wall mounting piece. Mirror Barb can function as a hand held mirror or a wall hung mirror.

The handle is shaped to be remain stable when placed on the table. The wall mounting piece has the shape of an hourglass to hang a hanger or a scarf.

Screws are included.
Wall plugs are not included.

DIMENSIONS (MM)

SMALL: H 97 / D 57 X Ø 210

LARGE: H 132 / D 57 x Ø 260

ITEM NO / COLOUR

150007 Small

150008 Large

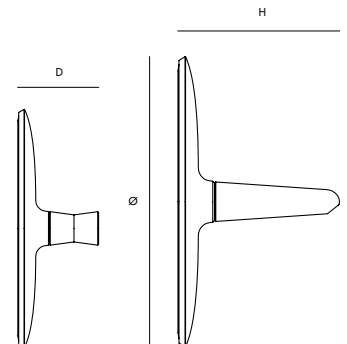



TIMEWATCH

DESIGNED BY AGATA NOWAK

MATERIALS

Oak, mirror glass, metal

DETAILED DESCRIPTION

Timewatch is made of oak veneer and safety mirror glass. The hands on the clock are painted metal.

When mounting Timewatch, it is optional where to place the clock. Two distance pieces should be added before mounting the mirror.

Screws are included.
Wall plugs are not included.

DIMENSIONS (MM)

H 344 x L 453 x D 6

ITEM NO / COLOUR

150009 Oak

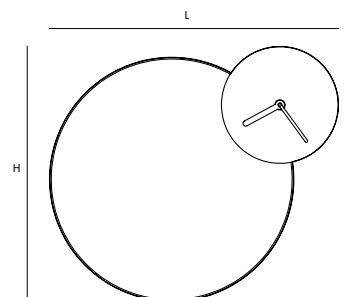



POCKET MIRROR

DESIGNED BY DANIEL SCHOFIELD

MATERIALS

Oak, safety mirror glass

DETAILED DESCRIPTION

Pocket Mirror is available in two sizes with either smoked stained oak, black painted oak or solid oak wood care.

Max. weight 3 kg

Screws are included.
Wall plugs are not included.

DIMENSIONS (MM)

SMALL: Ø 260 X D 102

LARGE: Ø 320 x D 133

ITEM NO / COLOUR

150010 Large, smoked stained oak

150011 Large, black

150012 Large, oak

150013 Small, smoked stained oak

150014 Small, black

150015 Small, oak

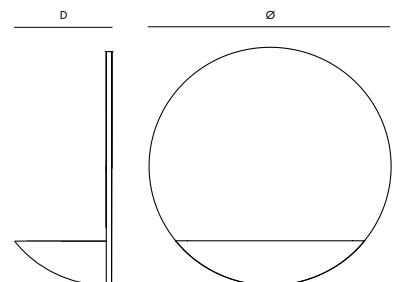

ACCESSORIES

RAINING CIRCLE

TIP, TAP, TOP

CLUSTER

LOOP TRAY

RACKET TRAY

GEM

NUNU

TAIL WING

HAAK

HINKEN

PIDESTALL

ILLUSION

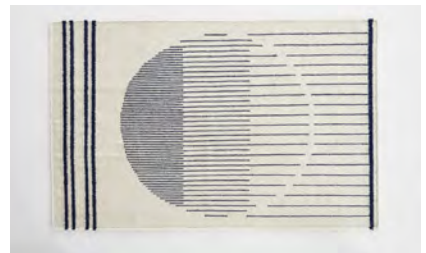
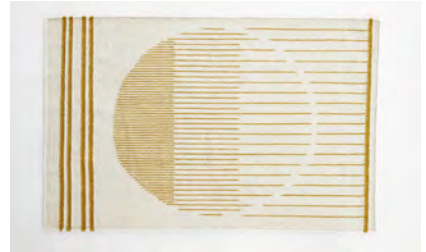
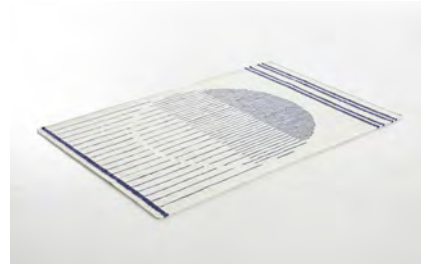

RAINING CIRCLE RUG

DESIGNED BY RIKKE MALLING

MATERIALS

Wool and cotton

DETAILED DESCRIPTION

Raining Circle is a hand woven rug. 40% New Zealand wool, 40% Indian wool, 20% cotton. Comes with two circular shaped brass wall mountings in the top of the rug.

Available in two sizes in either navy blue or yellow.

DIMENSIONS (MM)

SMALL: L 1400 X W 900

LARGE: L 2400 x W 1700

ITEM NO / COLOUR

160000 Large, Navy/white

160001 Large, Yellow/white

160010 Small, Navy/white

160011 Small, Yellow/white

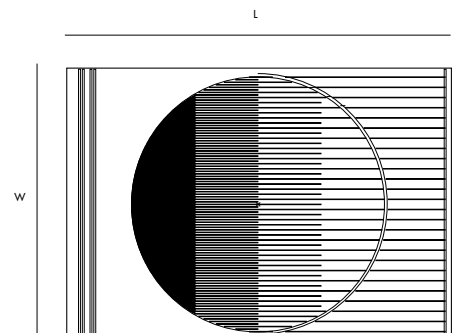



TIP, TAP, TOP CANDLE HOLDERS

DESIGNED BY BETTE EKLUND

MATERIALS

Metal

DETAILED DESCRIPTION

Tip, Tap, Tap candle holders are made of black painted metal.

Tip holds a standard candle, max 22 cm diameter

Tap holds a standard tea light, max 40 cm diameter

Top holds a standard pillar candle, max 70 cm diameter

DIMENSIONS (MM)

TIP: L 50 X D 30 X H 70

TAP: L 44 X D 64 X H 50

TAP: L 100 x D 84 x H 95

ITEM NO / COLOUR

150001 Tip, black

150000 Tap, black

150002 Top, black

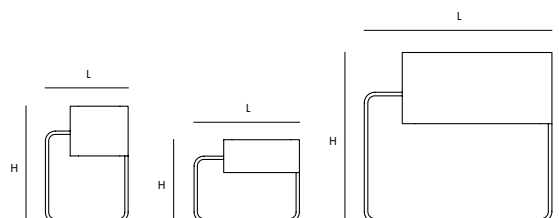



CLUSTER CANDLE HOLDER

DESIGNED BY SILJE NESDAL

MATERIALS

Metal

DETAILED DESCRIPTION

The Cluster series is made of wet white painted metal. Felt glides are attached on the bottom of the candle holders.

Cluster holds a standard candle,
max 22 mm diameter

DIMENSIONS (MM)

CLUSTER 1: H 78 X Ø 100

CLUSTER 2: H 48 X Ø 100

CLUSTER 3: H 28 x Ø 100

ITEM NO / COLOUR

150063 Cluster 1, white

150064 Cluster 2, white

150065 Cluster 3, white

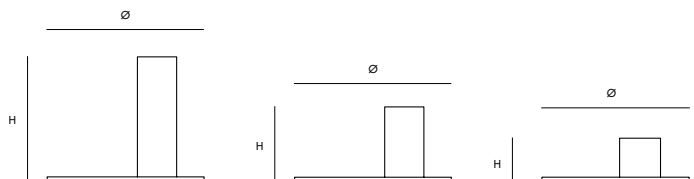



LOOP TRAY

DESIGNED BY JULIE TOLVANEN

MATERIALS

Oak, metal

DETAILED DESCRIPTION

Loop Tray is made of untreated solid oak. The handle is painted metal in either black or white. The handle folds down for easy storage or hanging. Notice that leaving greasy foods or candles will eventually leave marks on the board.

Food safe.

DIMENSIONS (MM)

SMALL: H 150 X Ø 215

LARGE: H 220 X Ø 325

ITEM NO / COLOUR

150020 Small, black handle

150021 Large, black handle

150024 Small, white handle

150025 Large, white handle

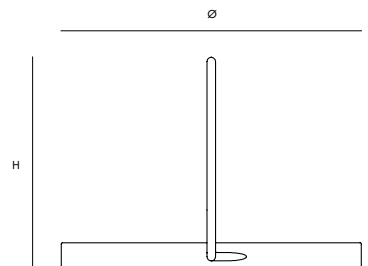



RACKET TRAY

DESIGNED BY TERKEL SKOU STEFFENSEN

MATERIALS

Oak

DETAILED DESCRIPTION

Racket tray is made of solid untreated oak/ oil treated smoked oak. The handle functions as a backstop, which makes Racket easy to place in upright position.

Complies with EN 71-3.
Food safe.

DIMENSIONS (MM)

SMALL: W 179 X L 164 X H 32
MEDIUM: W 279 X L 264 X H 32
LARGE: W 379 X L 364 X H 32

ITEM NO / COLOUR

150120 Large, smoked oak
150121 Large, oak
150122 Medium, smoked oak
150123 Medium, oak
150124 Small, smoked oak
150125 Small, oak

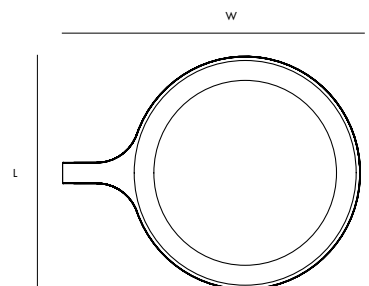



GEM ORGANISER

DESIGNED BY FRAII

MATERIALS

Oak

DETAILED DESCRIPTION

The Gem organiser is made of bended oak veneered plywood with a matt lacquer.

DIMENSIONS (MM)

SMALL: L 100 X D 100 X H 100

MEDIUM: L 130 x D 130 x H 130

ITEM NO / COLOUR

150050 Small, oak

150051 Large, oak

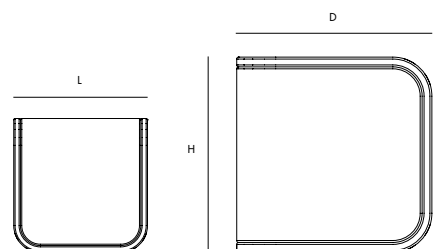



NUNU ELEPHANT

DESIGNED BY STEFFEN JUUL

MATERIALS

Oak

DETAILED DESCRIPTION

Nunu is made of solid oak. Its head can be tilted and detached from the body.

DIMENSIONS (MM)

SMALL: L 123 X W 112 X H 100

LARGE: L 180 x W 198 x H 160

ITEM NO / COLOUR

150030 Small, oak

150031 Large, oak

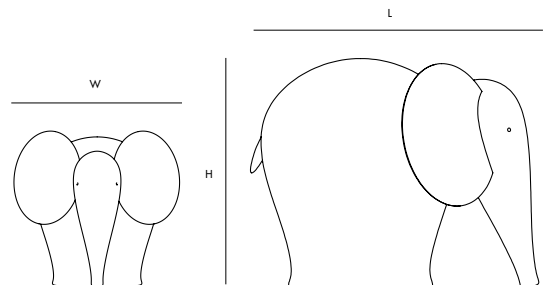

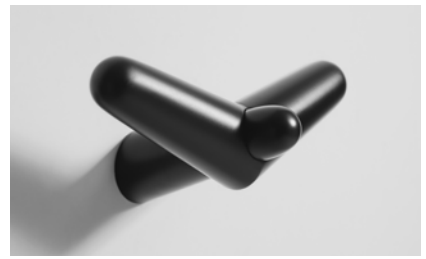

TAIL WING HOOK

DESIGNED BY KASPER NYMAN

MATERIALS

Oak

DETAILED DESCRIPTION

The Tail Wing hooks are made of solid oak. Available in solid oak and black painted oak with a metal bracket on the backside for easy wall mounting.

Max. weight 10 kg

Screws are included.
Wall plugs are not included.

DIMENSIONS (MM)

SMALL: L 130 X D 123 X H 75

MEDIUM: L 203 x D 127 x H 90

ITEM NO / COLOUR

150040 Small, oak

150041 Medium, oak

150042 Small, black

150043 Medium, black

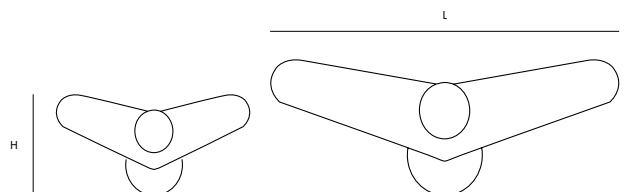

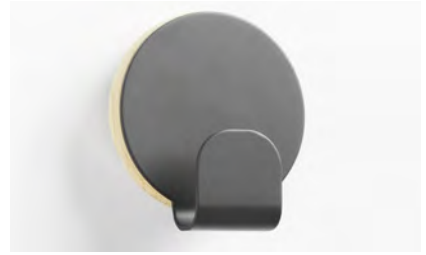

HAAK HOOK

DESIGNED BY RIKKE FROST

MATERIALS

Oak, metal

DETAILED DESCRIPTION

Haak is made of solid oak and dark grey /black painted metal. A metal bracket on the backside makes it easy for wall mounting.

Max. weight 10 kg

Screws are included.
Wall plugs are not included.

DIMENSIONS (MM)

H 90 x W 80 x D 43

ITEM NO / COLOUR

150038 Dark grey

150039 Black

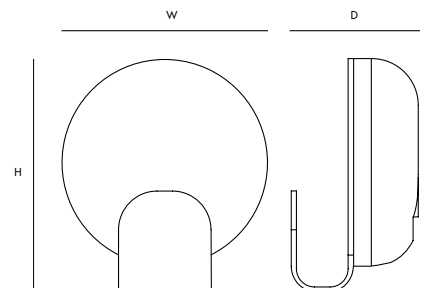



HINKEN FLOWERPOT

DESIGNED BY SILJE NESDAL AND ANN KRISTIN EINARSEN

MATERIALS

Ceramic

DETAILED DESCRIPTION

Hinken is a moss grey ceramic flowerpot series with a matt glazing on the outside and glossy glazing on the inside.

DIMENSIONS (MM)

HIGH: H 130 X Ø 160

MEDIUM: H 115 X Ø 180

LOW: H 85 X Ø 240

HIGH: H 95 X Ø 110 (Mini)

MEDIUM: H 60 X Ø 105 (Mini)

LOW: H 50 X Ø 150 (Mini)

ITEM NO / COLOUR

150102 High

150103 Medium

150104 Low

150105 Mini, high

150106 Mini, medium

150107 Mini, low

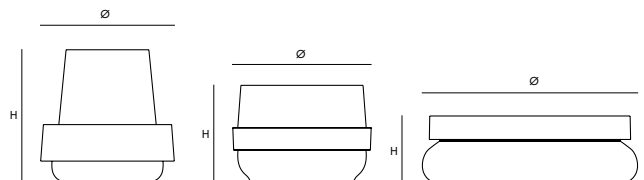



PIDESTALL FLOWERPOT

DESIGNED BY EMILIE STAHL CARLSEN

MATERIALS

Metal

DETAILED DESCRIPTION

The Pedestall flowerpots are made of powder coated metal. Available in three sizes and colours. Notice that before you plant your flowers, we recommend that you add plastic in the bottom of the flowerpot to protect the metal from moisture and water to avoid rust damages.

DIMENSIONS (MM)

SMALL: H 150 X Ø 150

MEDIUM: H 350 X Ø 400

LARGE: H 550 x Ø 400

ITEM NO / COLOUR

150108 Large, red

150109 Medium, blue

150110 Small, grey

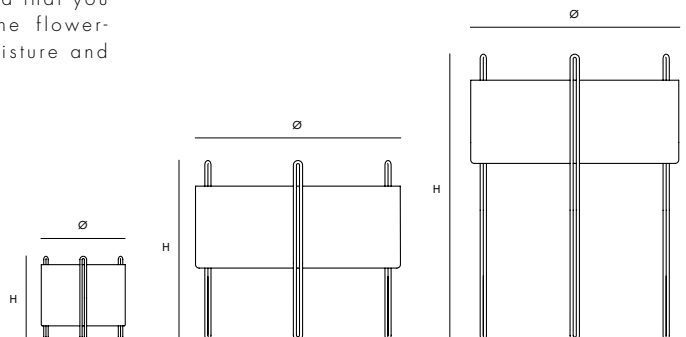



ILLUSION HANGER

DESIGNED BY PHILIP BRO

MATERIALS

ABS plastic

DETAILED DESCRIPTION

The Illusion hanger is made of ABS plastic. When on a hanger rail, Illusion will swing into a diagonal order and present the clothes or jackets on the hanger beautifully.

SALES UNIT

The Illusion hanger comes in sets of three pieces.

DIMENSIONS (MM)

L 425 x D 7,5 x H 233

ITEM NO / COLOUR

150100 White

150101 Black

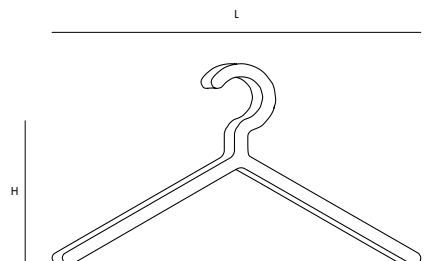

**WE
WOULD
LOVE TO
SAY
HELLO!**

WOUD COLLECTION 2017

Since our start in 2014, we have aimed at creating timeless design that can express personalities, evoke feelings, inspire people and create beautiful homes. We still hold on to that in our new collection. We have extended our first collection with an even broader and deeper selection of honest design. New talents have joined our design team from a wide range of countries such as Denmark, Germany, England and Japan. In our new additions, you will find interiors such as mirrors, trays, shelves and flowerpots. Each design has the simplistic Nordic feel with an international touch. We have handpicked the designs to make sure that each product has a meaning, a purpose and a function. We look forward to showing you what some of the most talented designers have come up with. We hope our collection will radiate 'love at first sight' for you. It surely does for us.